

1 2 3 4 5 6 7 8

A
B
C
D
E
F

A
B
C
D
E
F

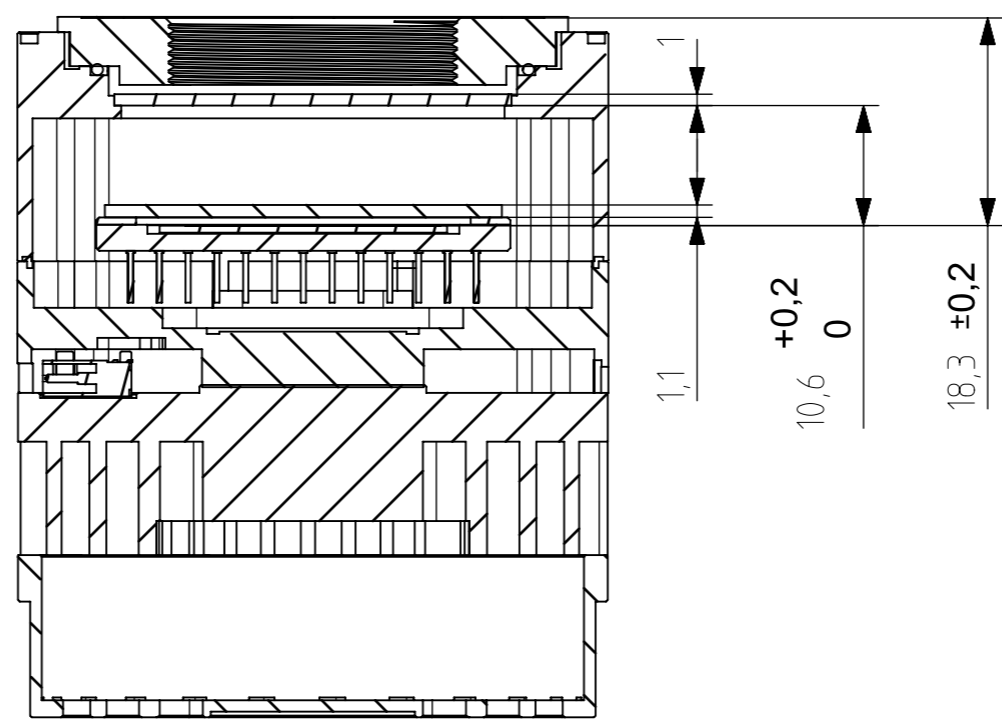

SECTION G-G

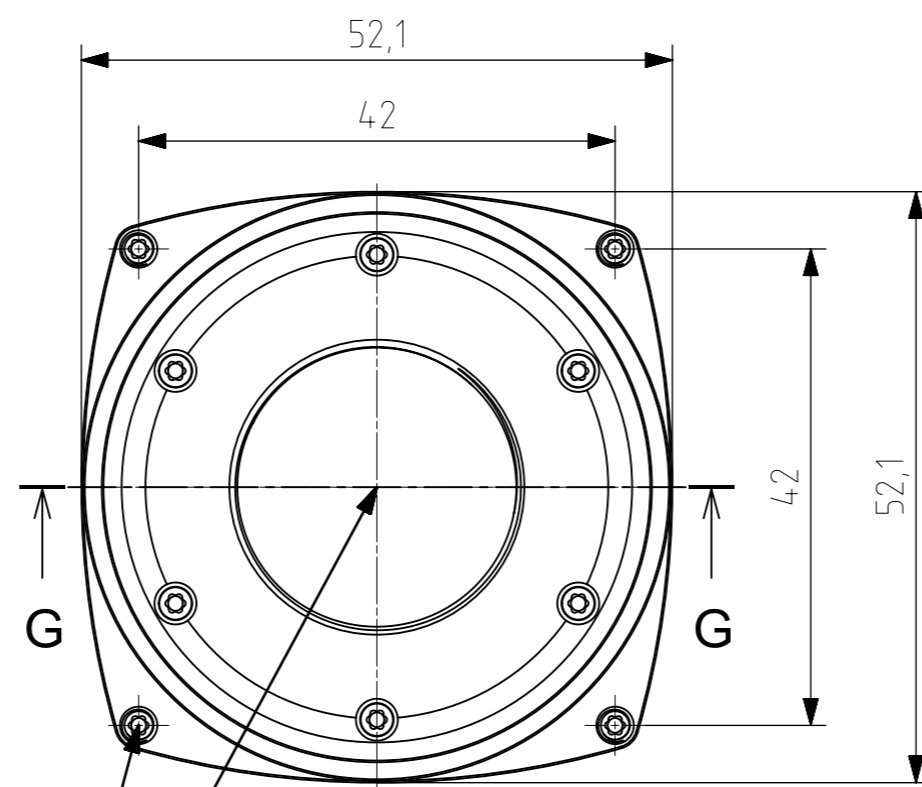
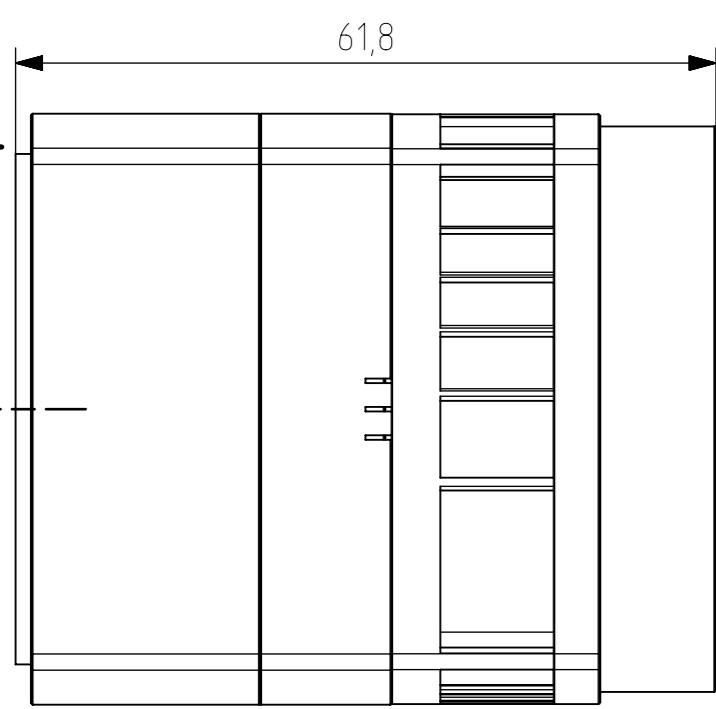
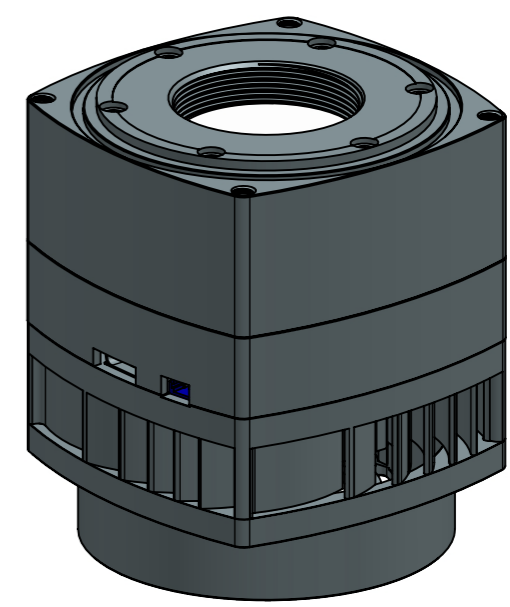

4x M3X0,5 ∇7
C mount thread
1-32 UN 2A ∇6

This drawings is the property of XIMEA s.r.o. No use thereof shall be made other than as a reference for proposals as submitted to XIMEA s.r.o. for jobs to be executed in conformity with such proposals unless the consent of said XIMEA s.r.o. has previously been obtained. No part of this drawing shall be copied or duplicated or its contents disclosed. The information contained on this drawing is confidential and proprietary.

Date:	Name:	PN:	Customer PN:	Surface Quality:
Designed -	SK	MJ042MR-GP-P11-BSI	NA	
Drawn 20190913	GS		Material:	Surface Finish:
Approved 20190913	GS	Project Class		
QC		MJ	First angle projection	Weight:
MFGP		Top Level Assembly		
Department: R&D	Default tolerances:		Units: mm	Scale: 1,5:1
		Change Date Name	Format	A3
Document Nr:			Doc Type: EU	Page: 1 of 1
			PART REVISION	DOCUMENT REVISION
			REV1	A



1 2 3 4 5 6 7 8 A3