

1 2 3 4 5 6 7 8

A

B

C

D

E

F

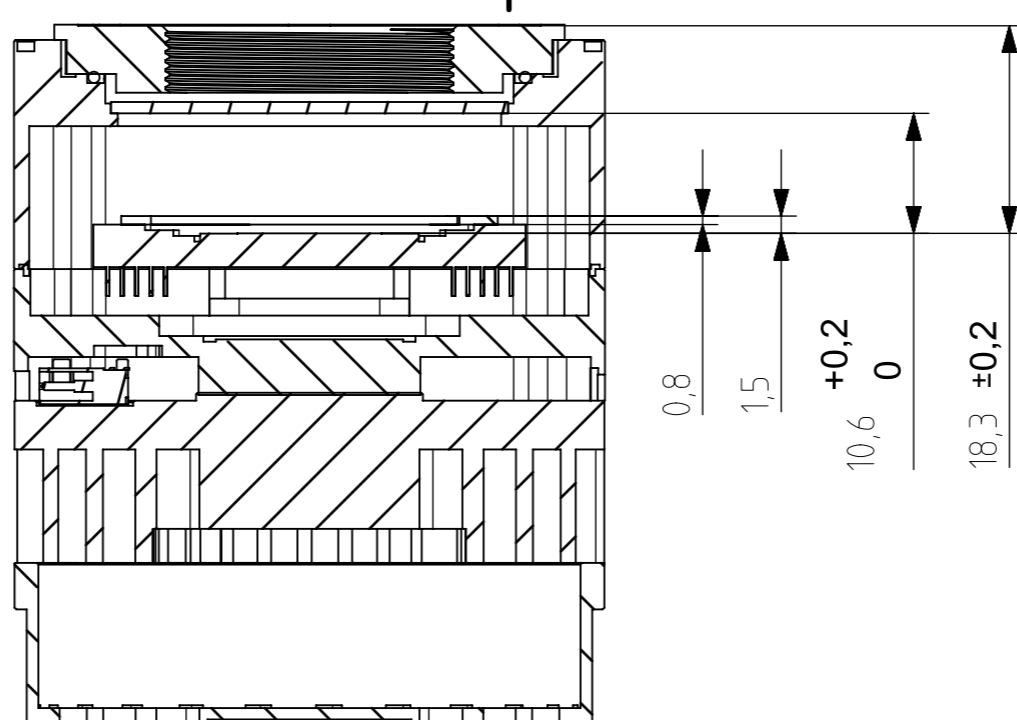

SECTION H-H

0,8
1,5
+0,2
0
10,6
18,3 ±0,2

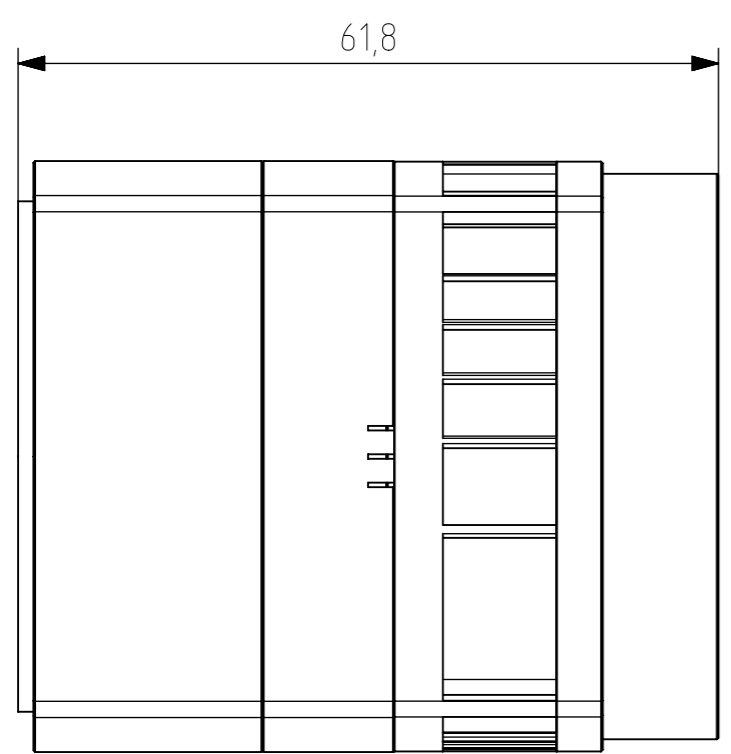
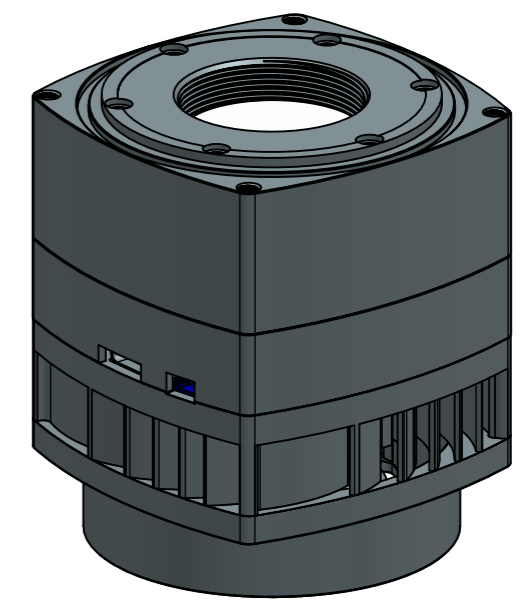

61,8

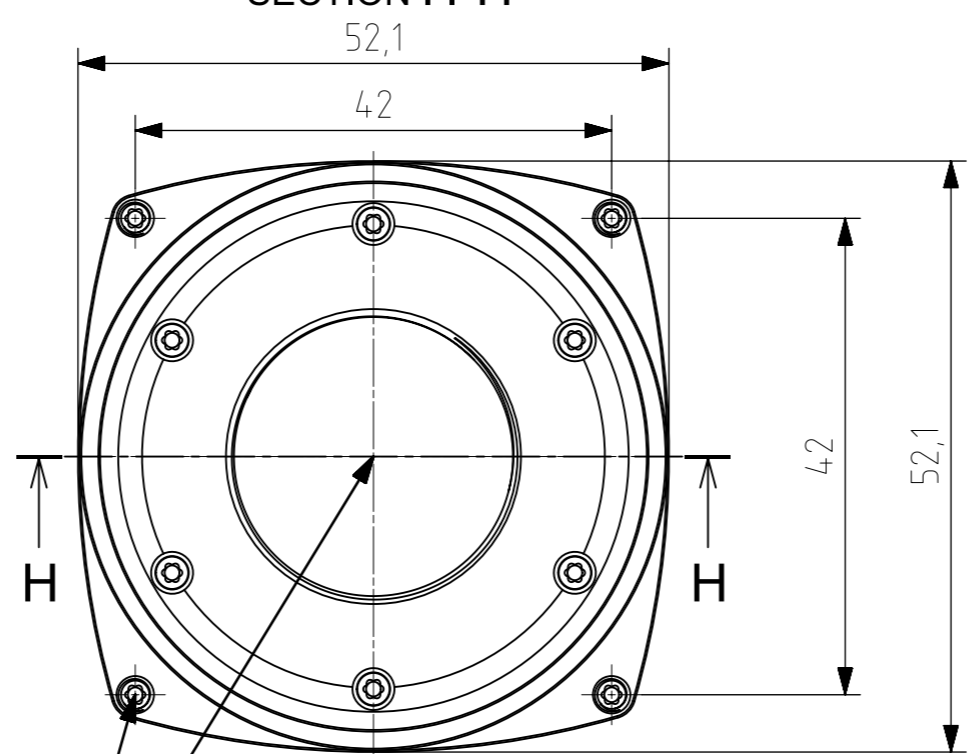

52,1

42



42

52,1

4x M3X0,5 ∇ 7
C mount thread
1-32 UN 2A ∇ 6

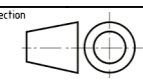

This drawings is the property of XIMEA s.r.o. No use thereof shall be made other than as a reference for proposals as submitted to XIMEA s.r.o. for jobs to be executed in conformity with such proposals unless the consent of said XIMEA s.r.o. has previously been obtained. No part of this drawing shall be copied or duplicated or its contents disclosed. The information contained on this drawing is confidential and proprietary.

Date:	Name:	PN:	Customer PN:	Surface Quality:
Designed -	SK	MJ150MR-GP	NA	
Drawn 20190913	GS	Project Class MJ Top Level Assembly	Material:	Surface Finish:
Approved 20190913	GS			
QC		First angle projection 	Weight:	
MFGP				
Department: R&D	Default tolerances:	Change	Date	Name
		Units: mm	Scale: 1,5:1	Format: A3
		Document Nr:	Doc Type: EU	PART REVISION: REV1
			DOCUMENT REVISION: A	Page: 1 of 1

A

B

C

D

E

F

1 2 3 4 5 6 7 8 A3