

This drawings is the property of XIMEA GmbH. No use thereof shall be made other than as a reference for proposals as submitted to XIMEA GmbH for jobs to be executed in conformity with such proposals unless the consent of said XIMEA GmbH has previously been obtained. No part of this drawing shall be copied or duplicated or its contents disclosed. The information contained on this drawing is confidential and proprietary.

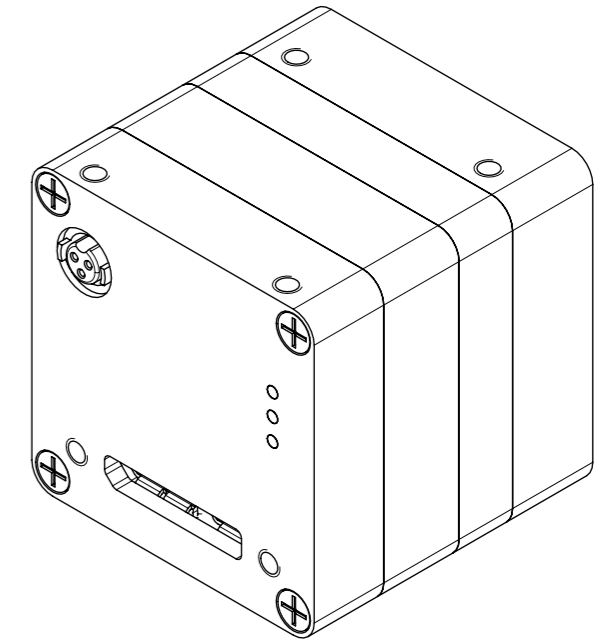
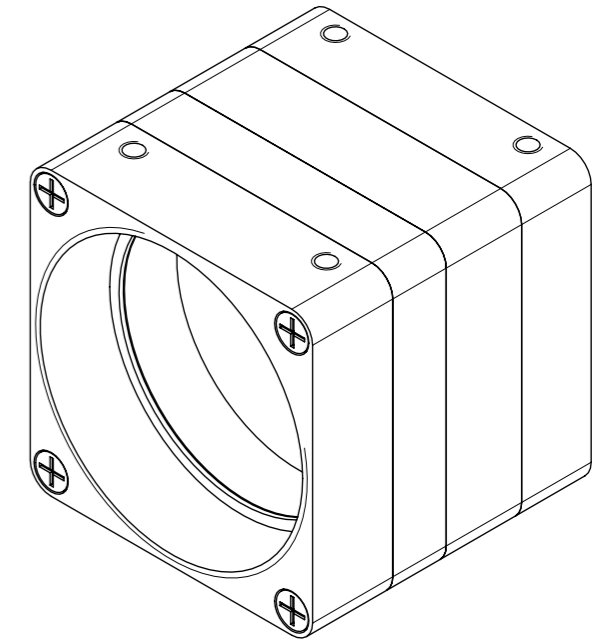
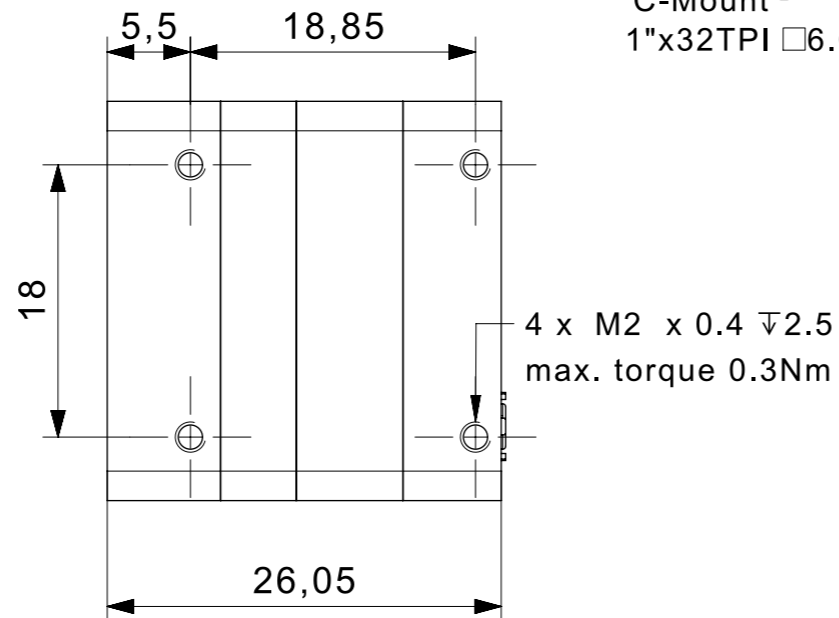
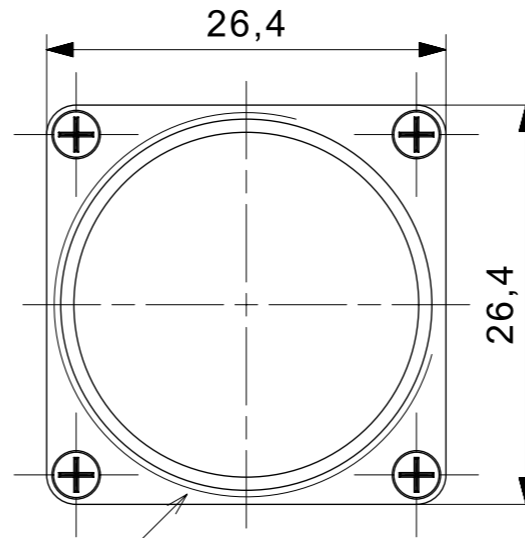
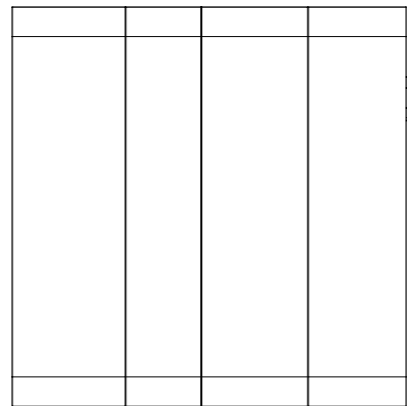
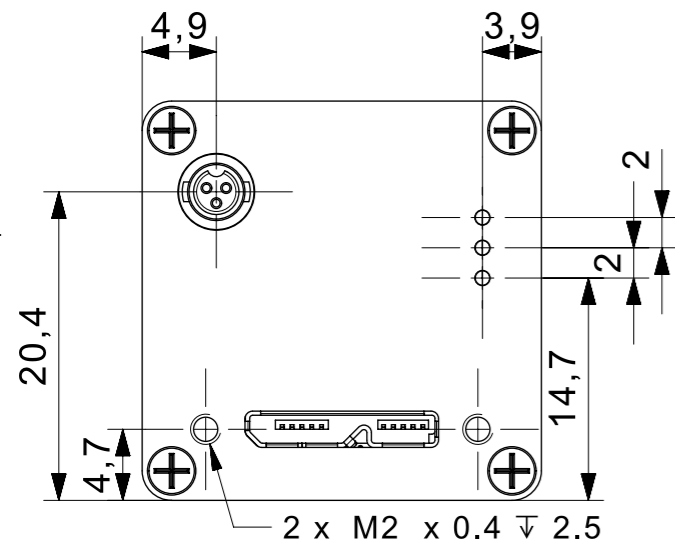
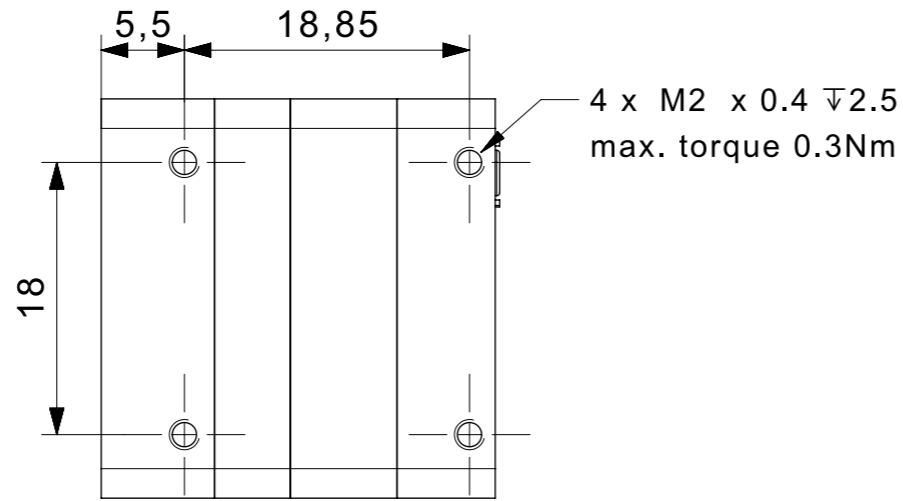

Date:	Name:	PN:	Customer PN:	Surface Quality:
20160920	SPAN0	MQ013xG-E2	NA	Ra 0.8
20160920	SPAN0		Material:	Surface Finish:
20160920	PINDROCH	Project Class	ENAW6061	OPTICAL BLACK
20160920	SPAN0	MQ	First angle projection	Weight:
20160920	SPAN0	Top Level Assembly	Units:	Scale: 2:1
Department:	Default tolerances:	Change	Date	Name
R&D	ISO2768-f	Doc Type:	Part Doc:	Version Revision
		Document Nr:	EU	1.0
				Page: 1 of 1