

This drawings is the property of XIMEA GmbH. No use thereof shall be made other than as a reference for proposals as submitted to XIMEA GmbH for jobs to be executed in conformity with such proposals unless the consent of said XIMEA GmbH has previously been obtained. No part of this drawing shall be copied or duplicated or its contents disclosed. The information contained on this drawing is confidential and proprietary.

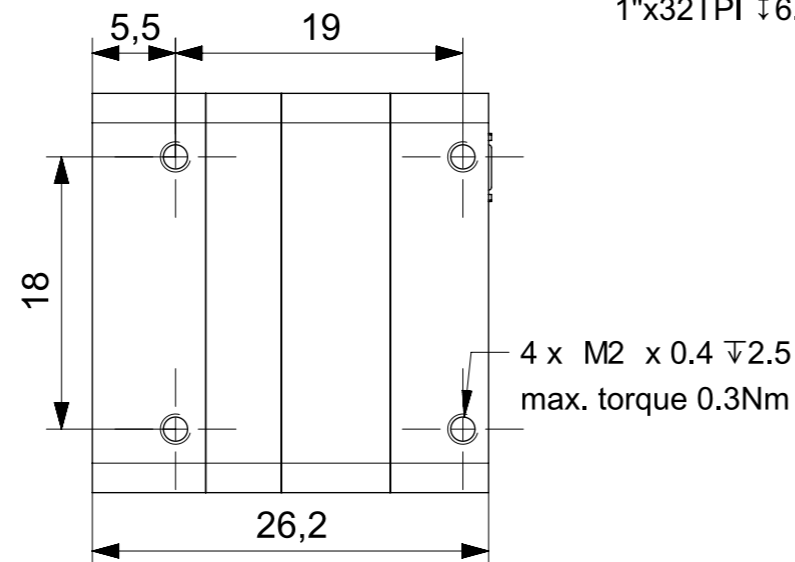
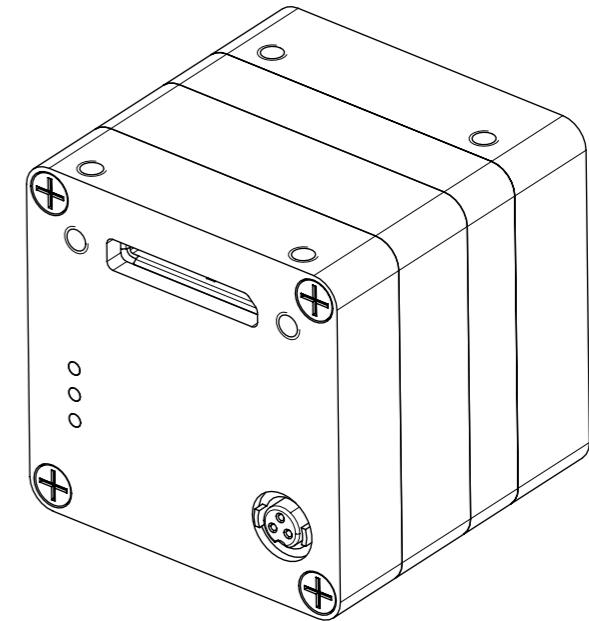
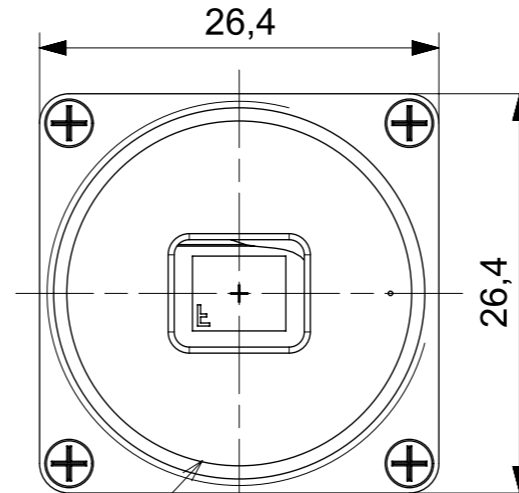
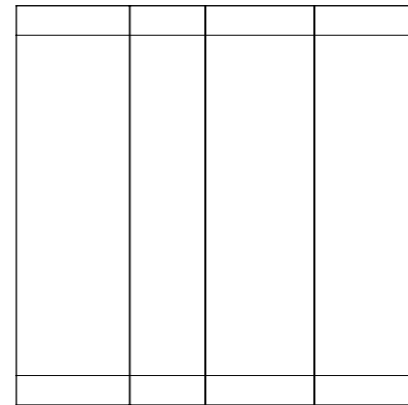
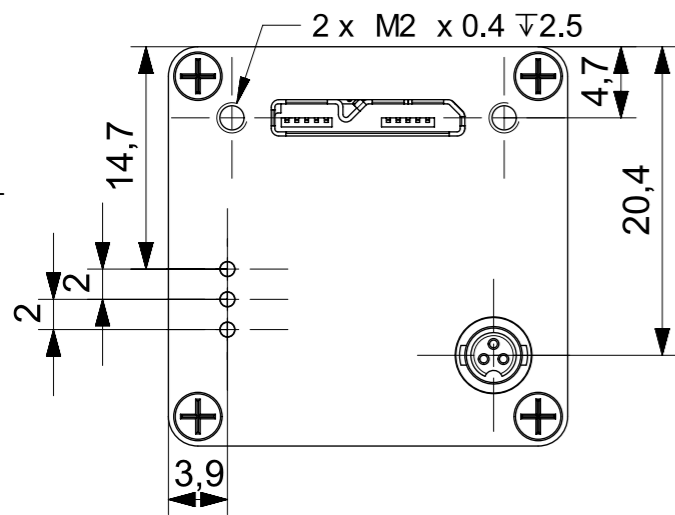
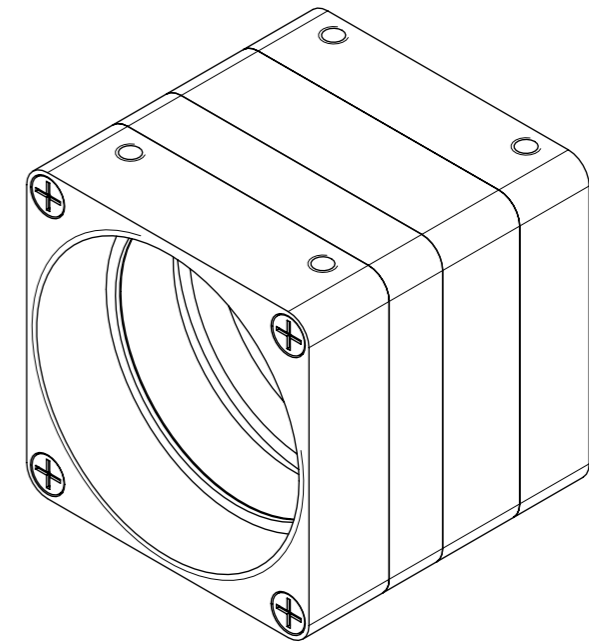
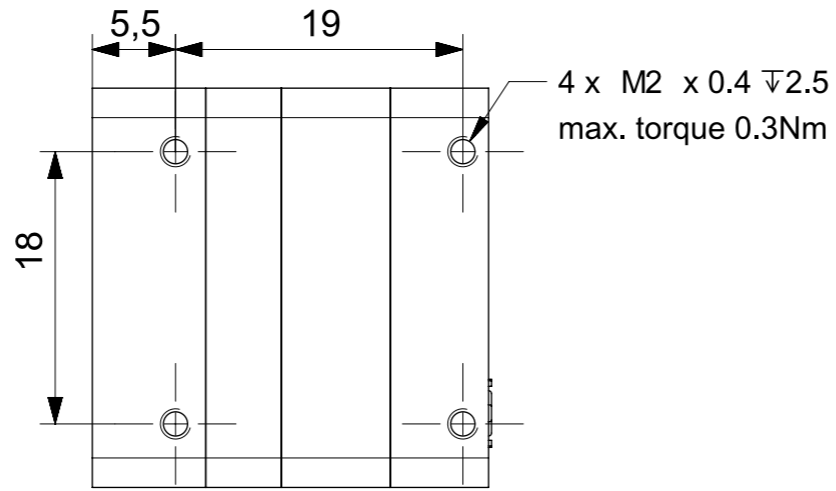

'C-Mount'
1"x32TPI ∇ 6.0

NOTES

Note 1:	NEVER EXCEED A MAXIMUM TORQUE OF 0.3Nm WHEN SCREWING THE M2 MOUNTING SCREWS
Note 2:	
Note 3:	

Date:	Name:	PN:	Customer PN:	Surface Quality:
20160920	SPAN0	MQ013xG-ON-C	NA	Ra 0.8
Designed	20160920	SPAN0	Material:	Surface Finish:
Drawn	20160920	SPAN0	ENAW6061	OPTICAL BLACK
Approved	20160920	PINDROCH	First angle projection	Weight:
QC	20160920	SPAN0		
MFGP	20160920	SPAN0	Units:	Scale: 2:1
Department:	Default tolerances:	Project Class	mm	Format
R&D	ISO2768-f	MQ		A3
		Top Level Assembly	Doc Type:	Part Doc:
		Change Date Name	EU	Version Revision
		Document Nr:		Page:
				1.0 1 of 1

