

1 2 3 4 5 6 7 8

A

B

C

D

E

F

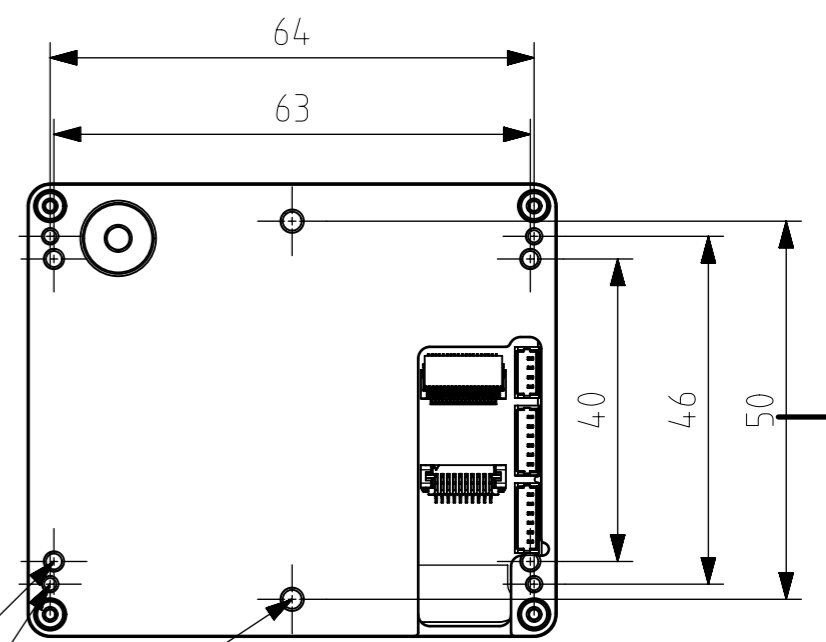
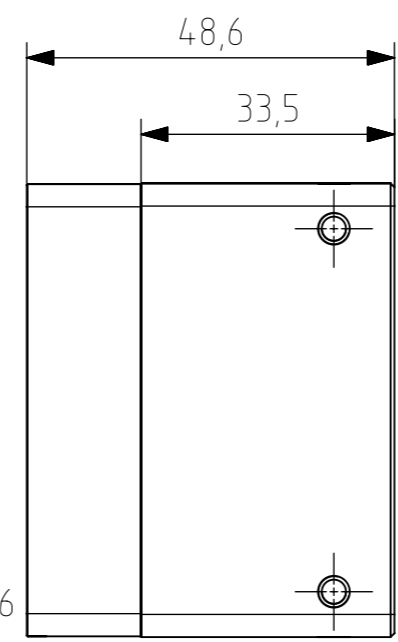
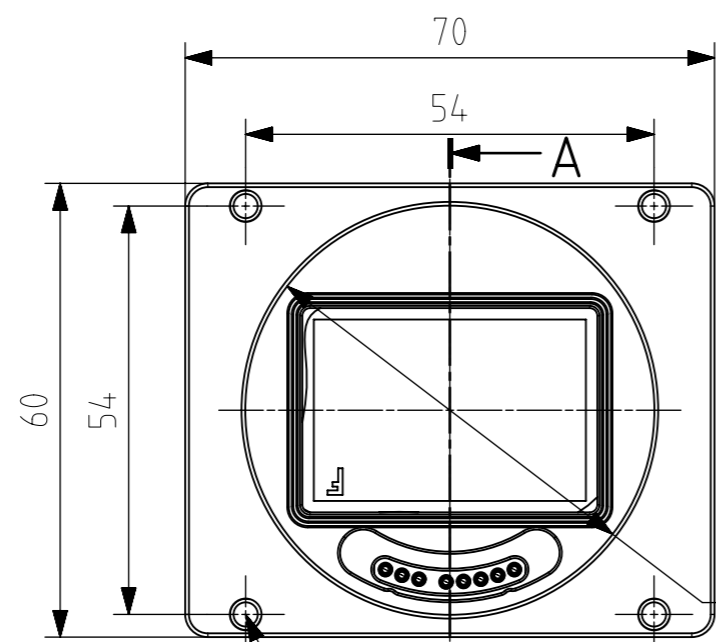
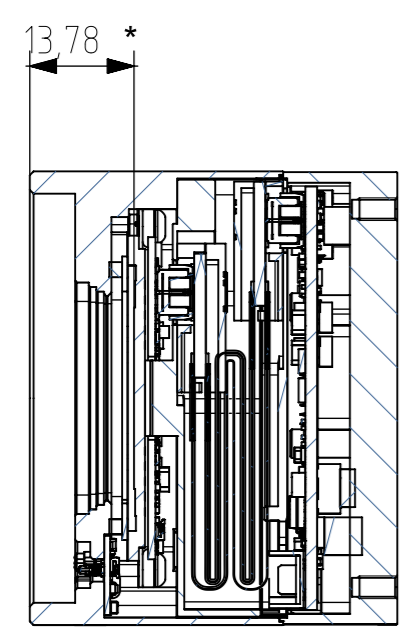
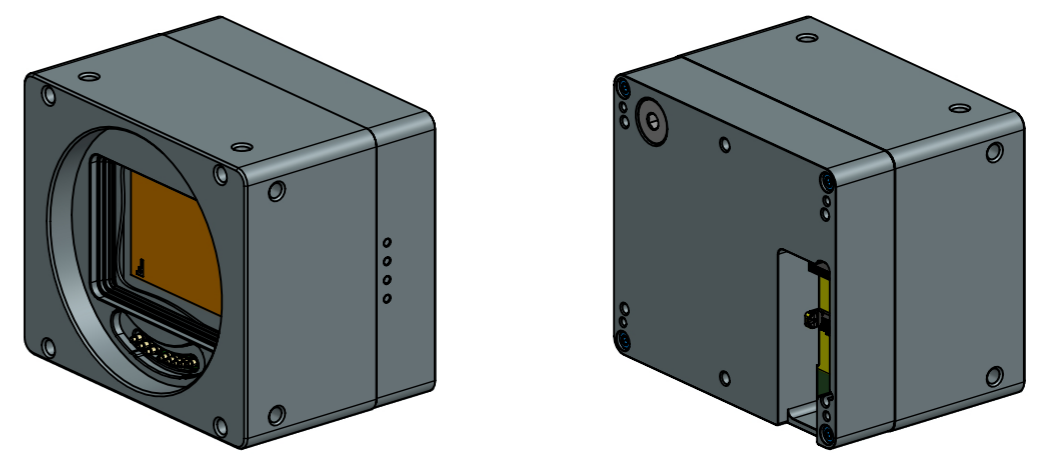
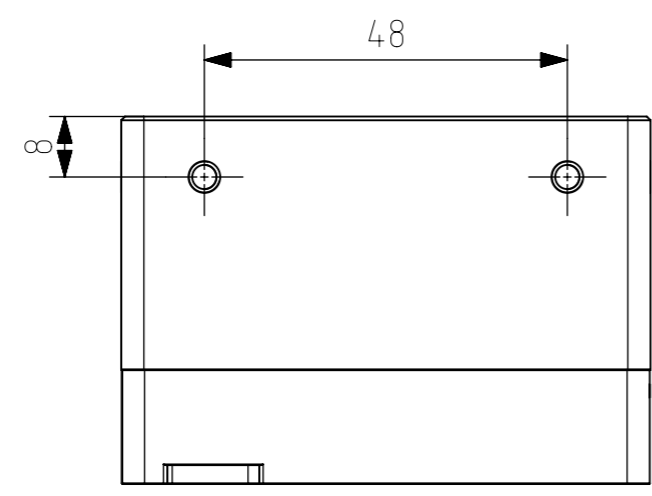

SECTION A-A

4x M4x0,7 ∇ 5

4x M2,5x0,45 ∇ 5
4x M2x0,4 ∇ 5
2x M3x0,5 ∇ 5

\varnothing 54,1 ∇ 6

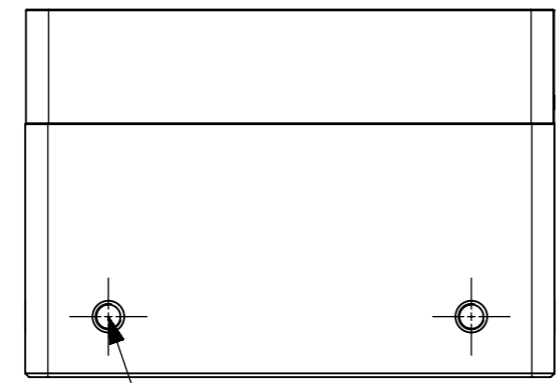
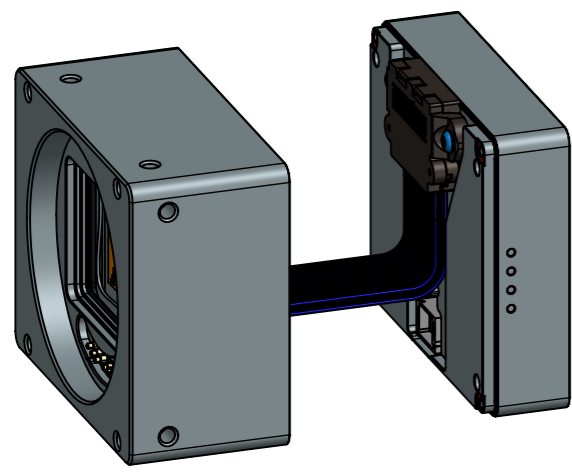

8x M4x0,7 ∇ 5

Cameras front and rear sub-assembly detached option

* Distance from the top surface area to the sensor active area

This drawings is the property of XIMEA s.r.o. No use thereof shall be made other than as a reference for proposals as submitted to XIMEA s.r.o. for jobs to be executed in conformity with such proposals unless the consent of said XIMEA s.r.o. has previously been obtained. No part of this drawing shall be copied or duplicated or its contents disclosed. The information contained on this drawing is confidential and proprietary.

Date:	20210513	Name:	R&D	PN:	MX610xR-SY-X4G3-FF	Customer PN:	NA	Surface Quality:	Ra
Designed	20210513	Drawn	20210528	Approved		Material:		Surface Finish:	
QC		MFGP		Department:	R&D	PN MFG		Weight:	
Default tolerance:		Change	Date	Name	Units:	Scale: 1:1	Format	A3	
Document Nr:		Doc Type:	EU	PART REVISION	A	DOCUMET REVISION	Page:	1 of 1	

