

5x M2x0,4 ∇ 2
Max torque 0.3Nm

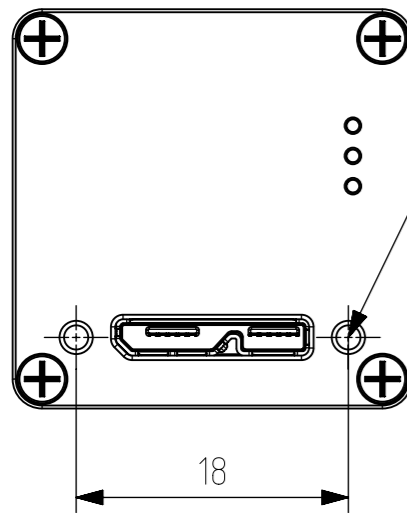

2x M2x0,4 ∇ 3,2
Max torque 0.3Nm

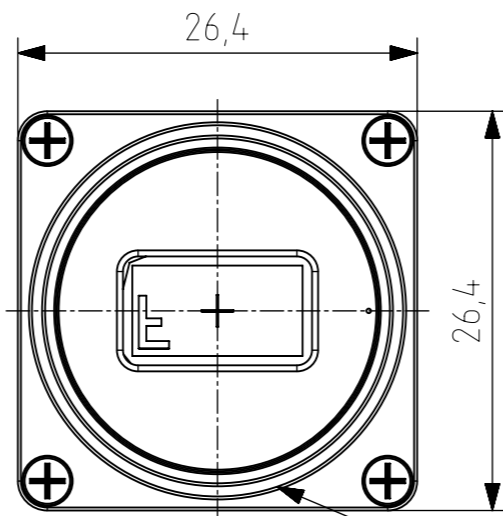

C-mount
1"x32TPI ∇ 6,0

5x M2x0,4 ∇ 2
Max torque 0.3Nm

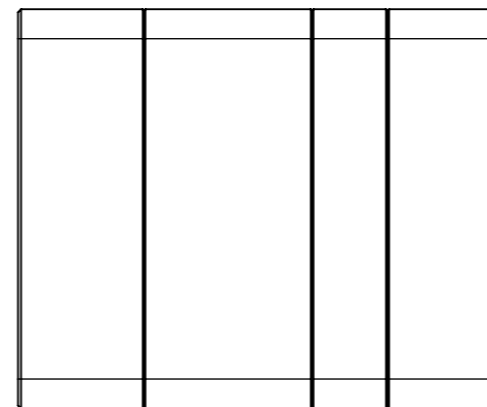
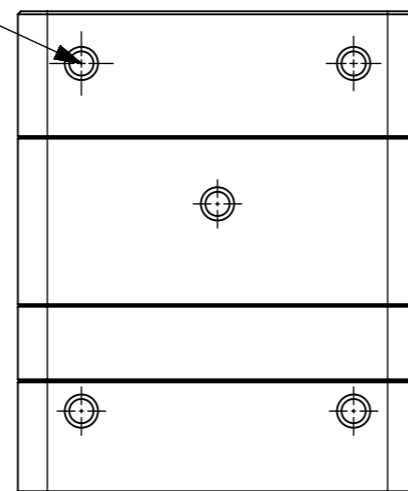

This drawings is the property of XIMEA s.r.o. No use thereof shall be made other than as a reference for proposals as submitted to XIMEA s.r.o. for jobs to be executed in conformity with such proposals unless the consent of said XIMEA s.r.o. has previously been obtained. No part of this drawing shall be copied or duplicated or its contents disclosed. The information contained on this drawing is confidential and proprietary.

Date:	20231303	Name:	R&D	PN:	MQ022x-CM-S7-NIO		Customer PN:	NA	Surface Quality:	Ra	
Designed	20231303	Drawn	20231303	QC	PN MFG		Material:		Surface Finish:		
Approved		QC		MFGP			First angle projection		Weight:		
Department:	R&D	Default tolerance:		Change	Date	Name	Units:	mm	Scale:	1:1	
							Doc Type:	EU	PART REVISION	A	
Document Nr:								Doc Type:	EU	REVISION	1 of 1